



REC-Duo unit (indoor)

REC^{duo} 100

Decentralised Heat Recovery Unit

including NZ Installation Kit

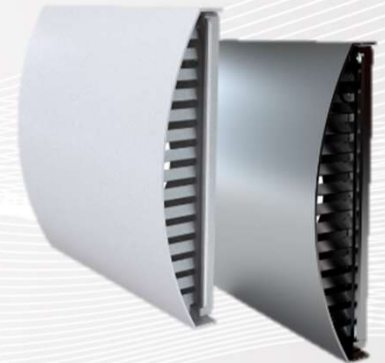

External vent (outdoor)



Where ventilation is required, the REC-Duo 100 is an innovative decentralized heat-recovery ventilation system, ideal for following situations:

- Single rooms with humidity or stale air problems
- Newbuilds with no ceiling space for ducting
- Retrofit projects and DIY (electrician required)
- Cost efficient solution to meet building code

The REC-Duo works best in pairs: Two units can be synchronised and work in Push-Pull mode. The PLUS RC version can be linked wireless to up to 5 further PLUS RC units.

INSTALLATION (through-wall)



Installation Kit

- Outdoor vent
- Plenum (for retrofit or walls <220mm)
- Trade seal
- Wall bracket

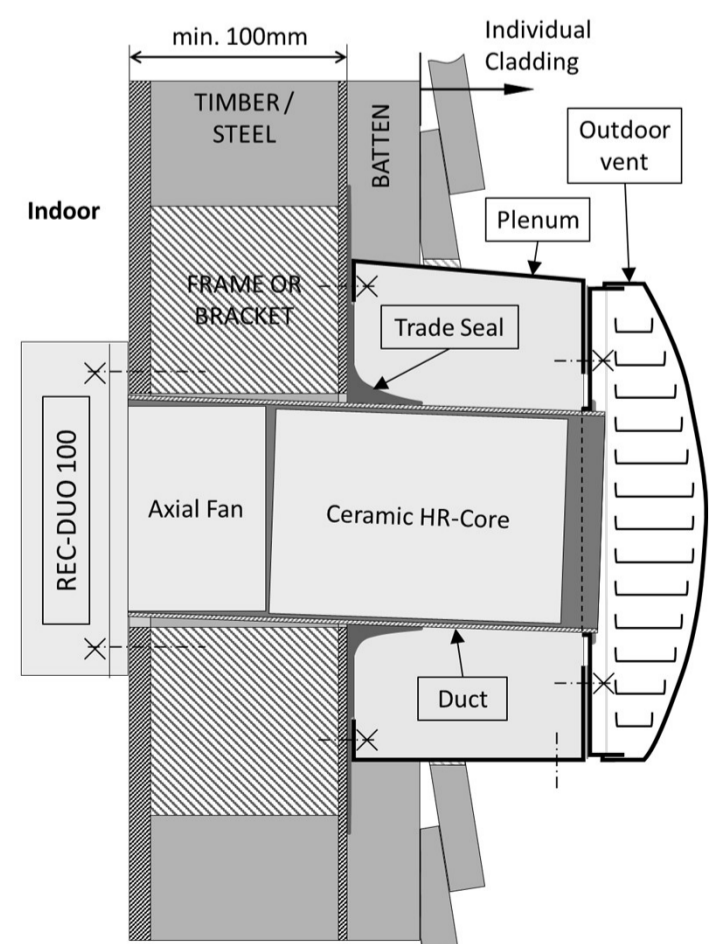

MODELS



REC duo 100 BASE

On/Off through light or dedicated switch (not included)



REC duo 100 MHY

Automatic increase/ decrease of fan speed according to the relative humidity (threshold is adjustable)



REC duo 100 PLUS RC

Comfort version with remote control to chose from 6 different operation modes, including humidity control. Can connect to 5 further PLUS RC unit.



HIGHLIGHTS

- 'Through-wall' ventilation system
- Heat recovery with up to 90% efficiency
- Effective removal of stale & humid air
- For rooms & areas up to 45m²
- Low running & maintenance cost
- Including NZ Installation Kit
- For retrofit & new-build

3 years warranty

COROSS FLOW INSTALL

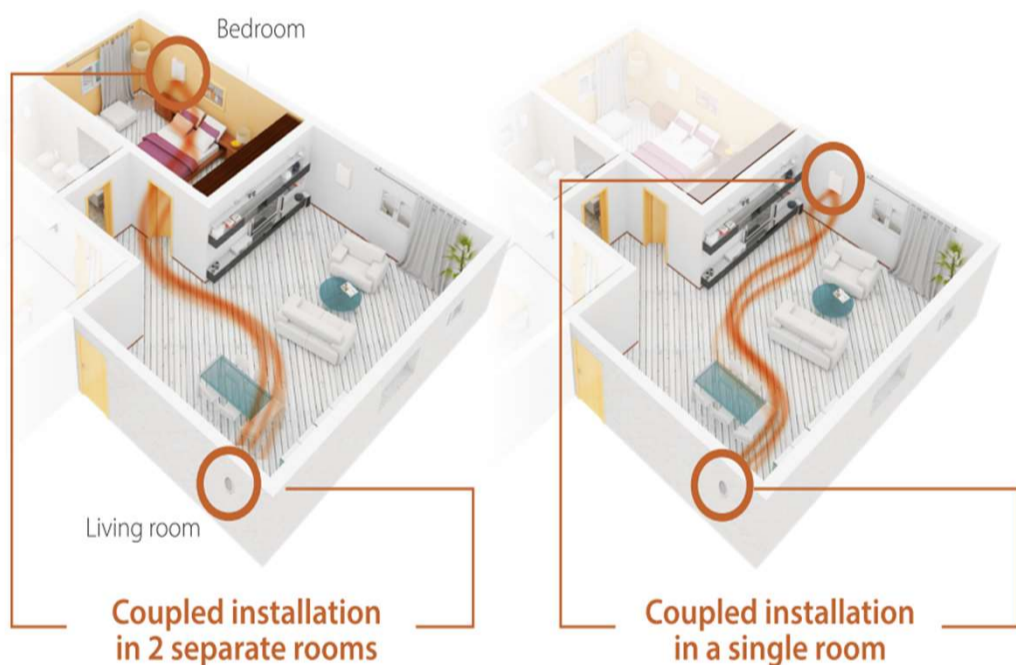

DIMENSIONS (in mm)

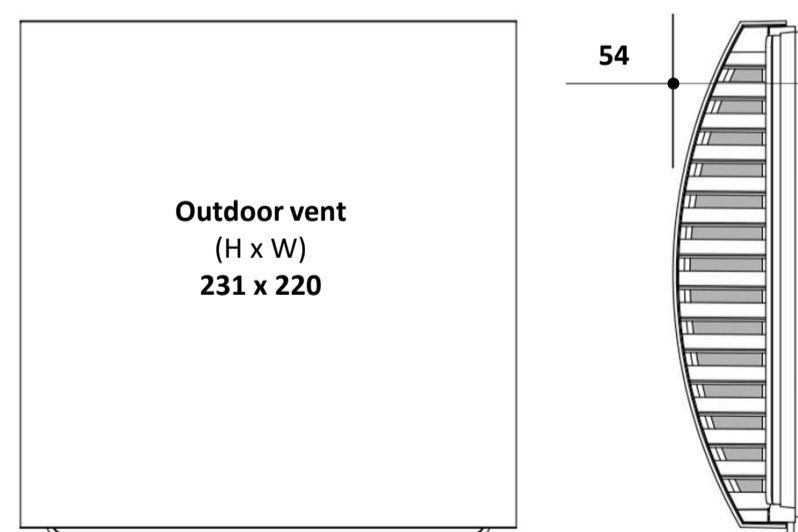
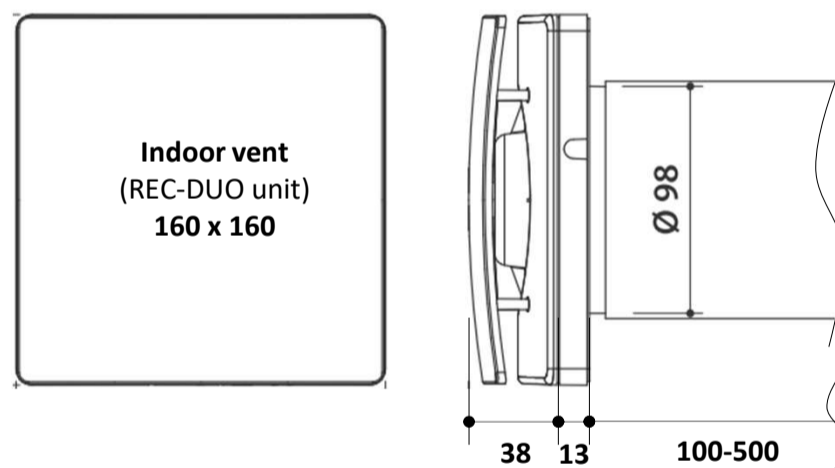

PERFORMANCE

| Air Flow min / max / only exhaust | Volt | Watt | Sound Pressure |
|---|------|-----------|-------------------|
| m ³ /h | V | W | dB(A)* |
| 12/30/40 | 230 | 1/2.8/3.5 | 15 / 29 |

*measured at 3m open field

Acceptable solution G4/AS1

 **solutionair**
your Expert for ventilation,
heating and cooling