

Stainless Steel Buffer Tank

Superior Finishing Quality

Carefully crafted with a high-quality finish for a sleek and professional appearance.

Ease of Installation

Engineered for straightforward setup with user-friendly connections. Equipped with multiple inlet configurations, accommodating various installation requirements.



Model		BTANKSS60	BTANKSS150
Volume	L	60	150
Number of Inlets		8	10
Connection Size	mm	25 F	32 F
External diameter / height	mm	D470 * H700	D470 * H1489
Internal diameter / height	mm	D370 * H550	D370 * H1389
Internal wall material/thickness		SUS304 /1.0mm	
Insulation material/thickness		Polyurethane Blowing/ 50mm	
External wall material/thickness		Baking Coated / 0.5mm	
Rubber mount		3	
Magnesium rod		Included	
Packing dimension	mm	545*545*865	545*545*1570
Net weight	kG	26	34
Gross weight	kG	27	37

150L Buffer Tank Diagram

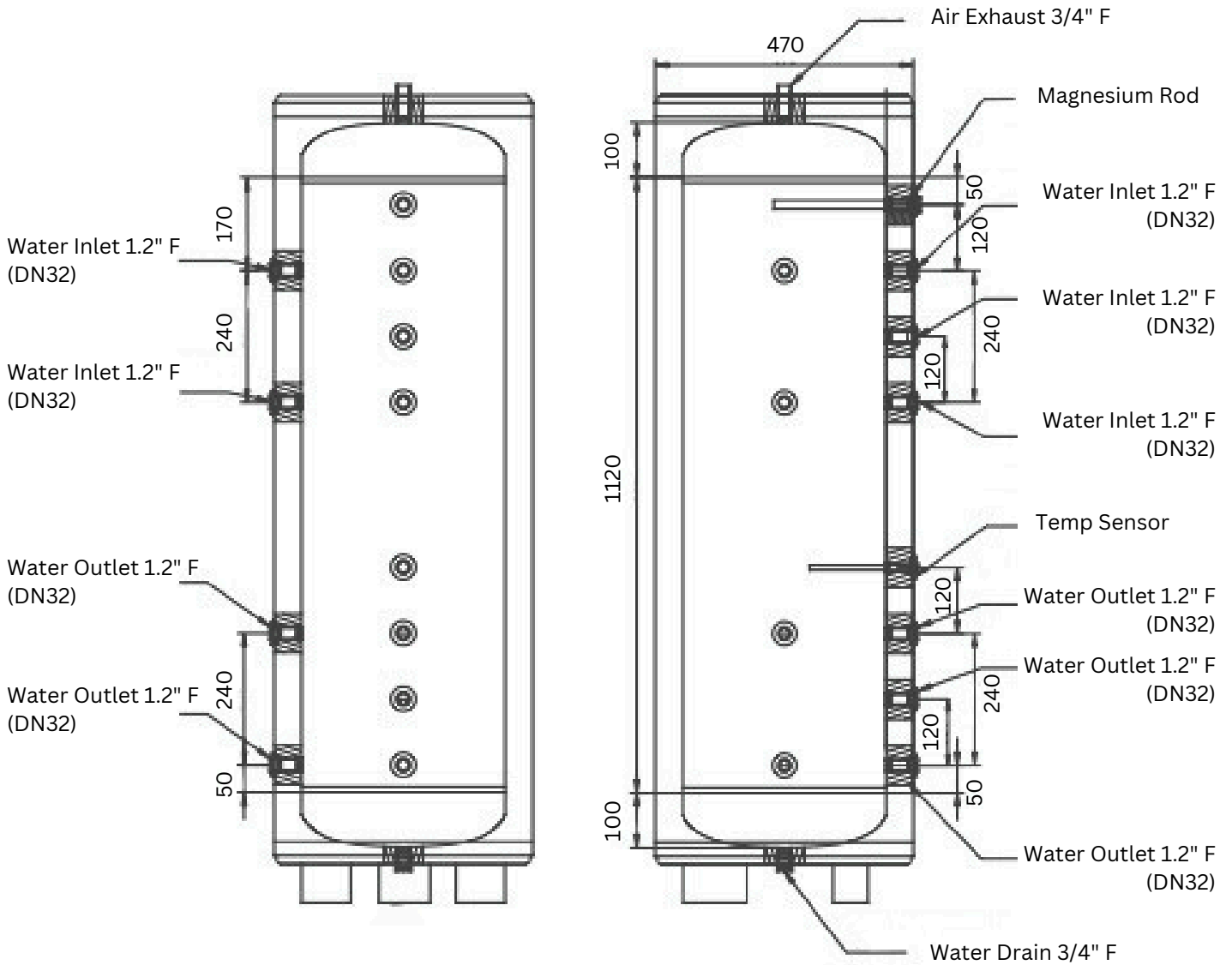

Durability

Constructed from premium stainless steel, offering corrosion, rust, and wear resistance for a long lifespan.



60L Buffer Tank Diagram

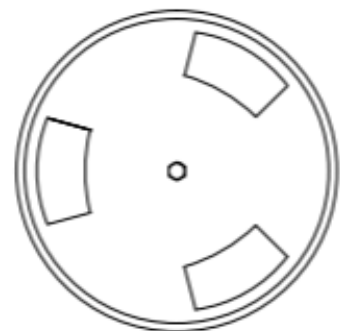
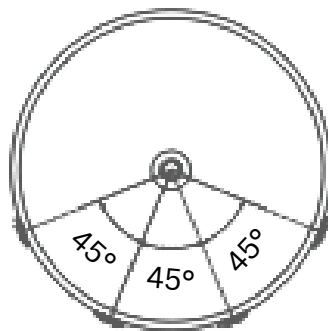
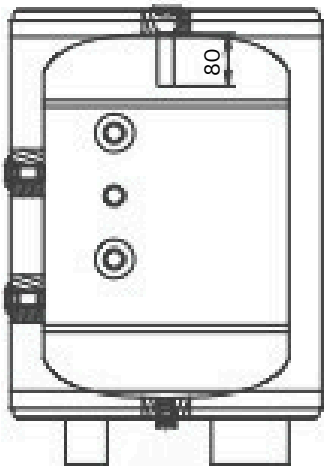
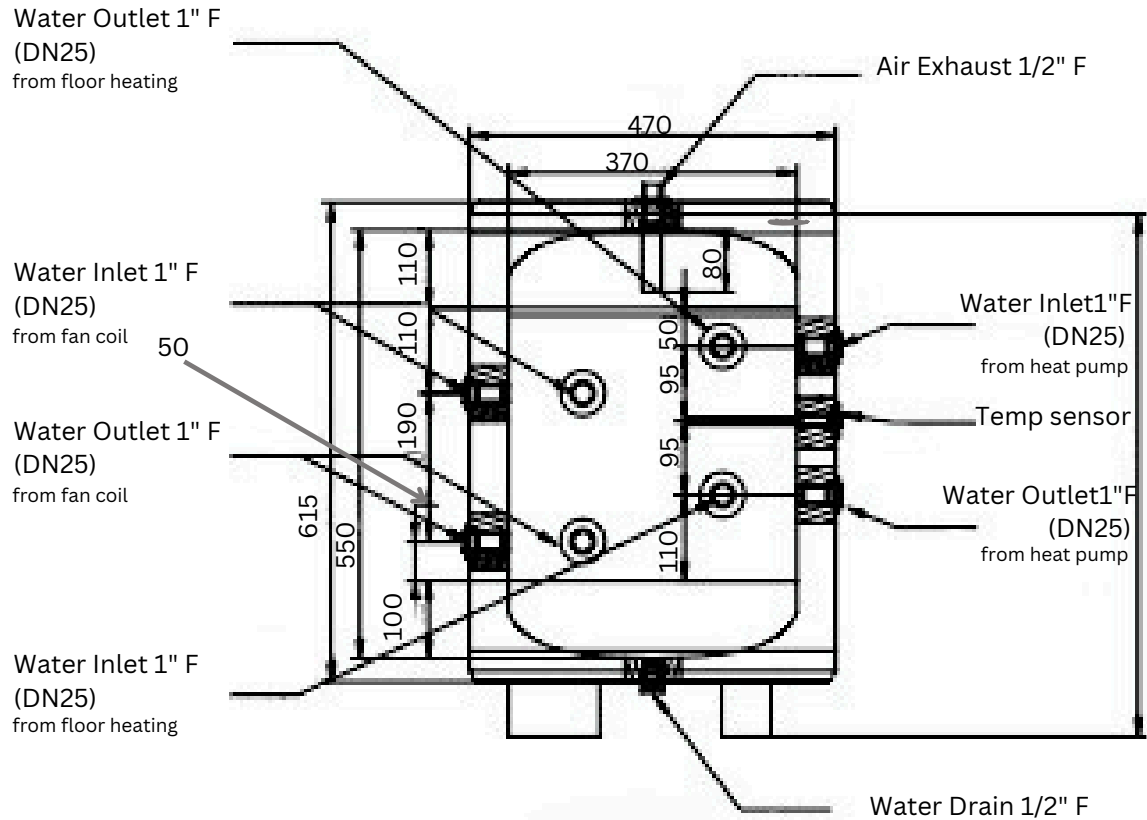

High Efficiency

Optimizes energy efficiency by maintaining stable temperatures and minimizing heat loss.

